

## When renewable energy (hydropower) demands an environmentally sound bearing

### The Problem

Selecting the right bearing for a Kaplan turbine in a 'river drop' situation

- Accessibility for maintenance essential
- Sleeve bearing ruled out because of risk of oil contamination of water
- Need to fully protect bearing from water ingress
- Low head of water, high flow (risk of bearing skidding, owing to light loading)

### The Solution

Cooper Bearings proposed a made-to-order 01BCF300mm EX C2 split anti-friction bearing with a spring-retained synthetic rubber seal (SRSRP) and a high temperature packing (HTP).

### The Benefits

- Accessibility is simpler, faster and safer than would have been the case with a solid anti-friction bearing, thanks to the split structure pioneered by Cooper
- Unlike a sleeve bearing, the Cooper solution needs no separate lubrication system, thus dramatically reducing the risk of river contamination
- The SRSRP/HTP seal and packing combination is highly effective in keeping river water out of the bearing
- Cooper's C2 specification has a tighter internal clearance, eliminating the risk of skidding and so protecting the turbine shaft
- Additional benefits cited by the OE manufacturer were low energy consumption, economical pricing and the simplicity of the solution.

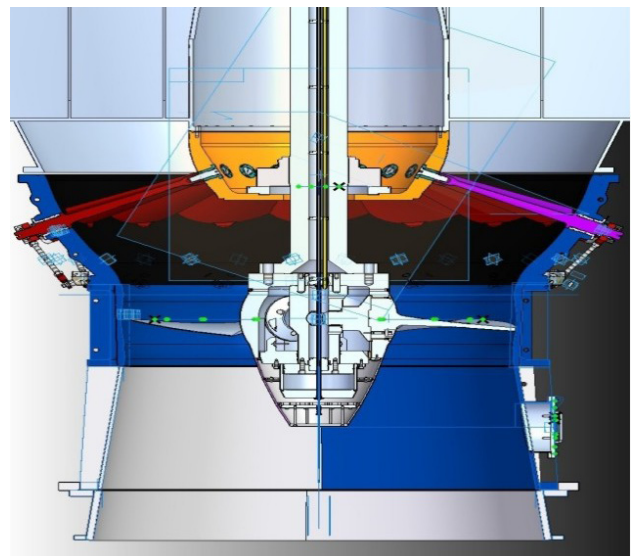

## Up-to-the-minute experience combined with unique facilities for custom design and build

Cooper Bearings' in-depth experience with OE turbine manufacturers in Austria, Italy, Spain, France and Canada weighed heavily in the manufacturer's buying decision in this case. It was complemented by Cooper's unique ability to tailor even the largest bearings, to the most exacting specifications, to precisely fit the needs of the installation.

For more information, contact us via our website [www.cooperbearings.com](http://www.cooperbearings.com)